

HEPA Filter Module

For critical air environments

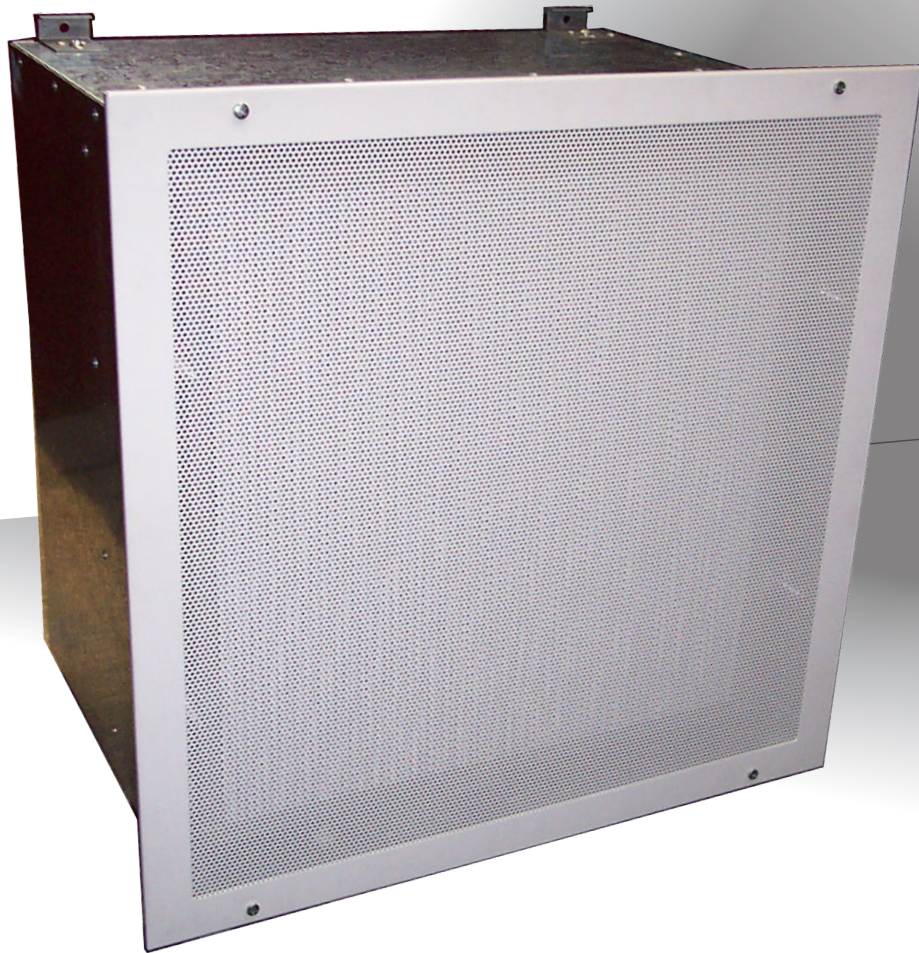

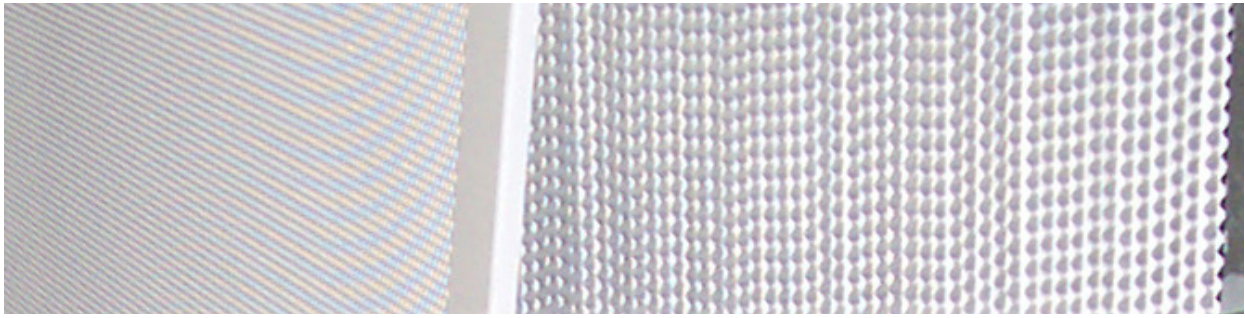

Applications

HEPA filter modules are designed for use in critical applications where product or personnel protection requires an environment free of airborne contaminants.

- Operating theatres
- Clean room facilities
- Pharmaceutical manufacture
- Electronics industry
- Food processing
- Optics

Description

The HEPA filter module is fully manufactured in Australia to conform with the performance requirements of AS 1386. It comprises a HEPA filter in a galvabond housing with an attractively styled fascia and the option of an integral fan/blower.

Construction

Housing: Constructed from quality galvabond.

Fascia: Filter guard is satin polished 304# stainless steel or white painted finish.

Fan: A variable speed direct drive blower that enables airflow adjustment as required.

Filter: HEPA type, strictly conforming with AS 4260.

Power: Provided via a single phase 240 V, 10 amp 3 pin plug.

Filter seals: Modules can be supplied with either gasket or fluid seal HEPA filters.

Performance

HEPA filters are individually tested on a NATA accredited Hot DOP test rig to AS 4260 and filter efficiency is always guaranteed. To pass inspection each filter must achieve an efficiency of 99.99%.

Modules are individually tested to conform with AS 1386 - sound level not exceeding 62dBA on a free field basis.

Standard specification

HEPA filter modules shall conform with AS 1386. A NATA accredited laboratory shall test modules and the manufacturer shall provide a certificate showing test results for the purpose of establishing full compliance with AS 1386. Individual HEPA filters shall be tested to AS 4260.

Installation

HEPA filter modules must be supported independently from the ceiling structure. The module's power supply must be interlocked with the air conditioning unit in such a way as to start the module fan before starting the air conditioner fan.



Construction

HOUSING	Constructed from quality galvabond.
FASCIA	Filter guard is satin polished 304# stainless steel or white painted finish.
FAN	A variable speed direct drive blower that enables airflow adjustment as required.
FILTER	HEPA type, strictly conforming with AS 4260.
POWER	Provided via a single phase 240 V, 10 amp 3 pin plug.
FILTER SEALS	Modules can be supplied with either gasket or fluid seal HEPA filters.

Maintenance and Service

To ensure conformity with AS 1386, HEPA filter modules should be inspected and tested on site:

- before use
- on at least an annual basis
- after modification
- after relocation
- when HEPA filter is renewed

On Site Testing

All HEPA filters shall be tested to AS 1807.6 or 1807.7 by AES Environmental or other NATA accredited laboratory.



AES Environmental maintains an ISO 9001:2015 quality management system to ensure process and product conformance.



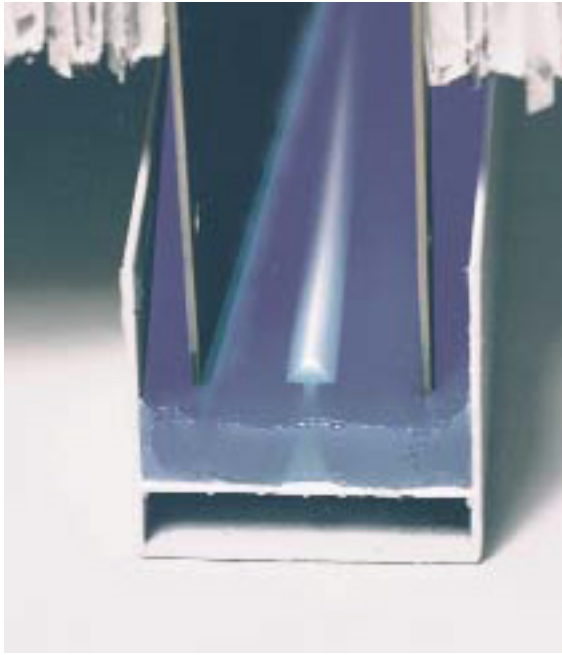

'BlueGel' Filter sealing arrangement

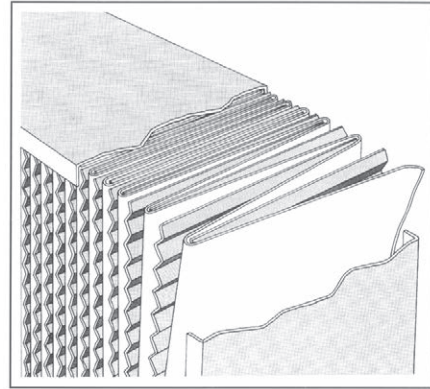

Conventional HEPA construction



Channel Ceil HEPA

Gel Seal Filter Frame Sealant

Gel-Seal is a unique, ice-blue silicone gel specifically designed to create and preserve an airtight seal between high-efficiency particulate air filters and their holding frames or housings.

The gel is factory-installed and factory-cured in the perimeter channels of filters designed for fluid seal applications. The cured gel has the self-healing qualities of a liquid while retaining the stability and non-flow characteristics of a solid.

These properties are maintained at both high and low temperature extremes and are not lost even when aged continuously at high temperatures. Gel-Seal exhibits excellent bonding characteristics to many

materials, it is also highly self-adhesive, allowing knife edges and filter skirts to be cleanly withdrawn. The hydrophobic nature of the gel makes it ideally suited for applications that require long-term sealing against moisture and other atmospheric contaminants.

HEPA Media Construction

The glass-paper filtering medium is pleated into a narrow vee formation and held in place by corrugated aluminum separators inserted between the pleats. This forms the filter element which is bonded into a rigid corrosion-resistant steel frame with all joints encapsulated and sealed in a special urethane elastomer.



Performance Data

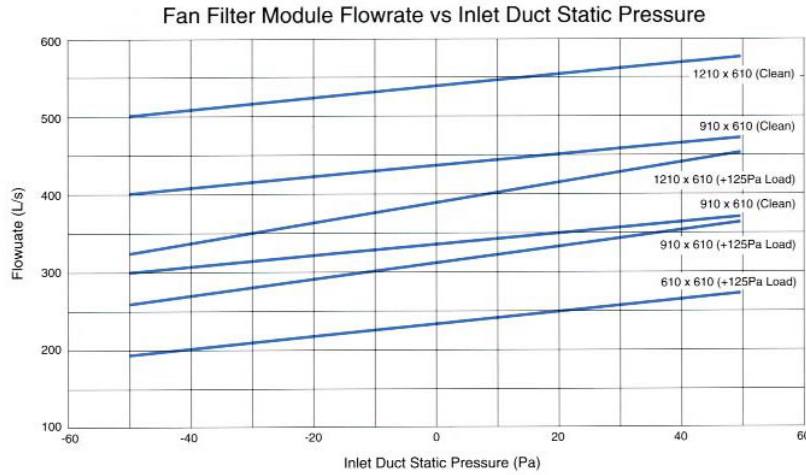

Low Profile Fluid Seal Fanless Filter Module

(Filter accessible from room)

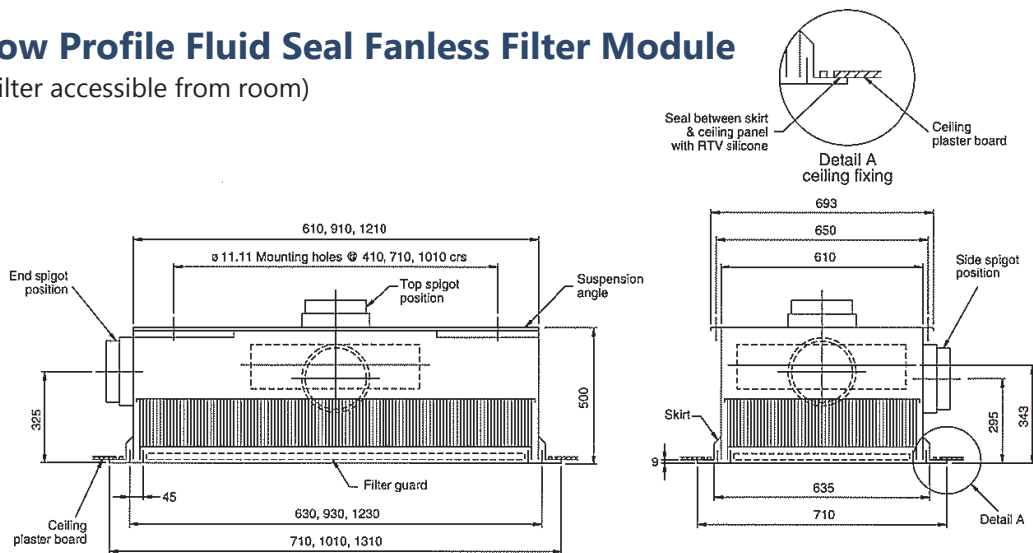

Engineering data

Clean capacity(L/s)	Filter plenum static press.(Pa)	Capacity# (AS1386)	Flow direction	Filter seal*	Nominal size (mm)			Spigot location	Spigot dia.(mm)**	Installed weight (kg)	Part number
					Length	Width	Height				
340	300	175	Supply	Fluid	610	610	500	Side	300	40	1687-1706/1
445	275	272	Supply	Fluid	910	610	500	Side	300	59	1687-1706/2
545	250	370	Supply	Fluid	1210	610	500	Side	300	74	1687-1706/3
340	300	175	Supply	Fluid	610	610	500	End	300	40	1687-1706/4
445	275	272	Supply	Fluid	910	610	500	End	300	59	1687-1706/5
545	250	370	Supply	Fluid	1210	610	500	End	300	74	1687-1706/6
340	300	175	Supply	Fluid	610	610	500	Top	300	40	1687-1706/7
445	275	272	Supply	Fluid	910	610	500	Top	300	59	1687-1706/8
545	250	370	Supply	Fluid	1210	610	500	Top	300	74	1687-1706/9
340	300	175	Supply	Fluid	610	610	500	Side	500Wx200H	40	1687-1706/13
445	275	272	Supply	Fluid	910	610	500	Side	500Wx200H	59	1687-1706/14
545	250	370	Supply	Fluid	1210	610	500	Side	500Wx200H	74	1687-1706/15
340	300	175	Supply	Fluid	610	610	500	End	500Wx200H	40	1687-1706/16
445	275	272	Supply	Fluid	910	610	500	End	500Wx200H	59	1687-1706/17
545	250	370	Supply	Fluid	1210	610	500	End	500Wx200H	74	1687-1706/18
340	300	175	Supply	Fluid	610	610	500	Top	300Wx300H	40	1687-1706/22
445	275	272	Supply	Fluid	910	610	500	Top	300Wx300H	59	1687-1706/23
545	250	370	Supply	Fluid	1210	610	500	Top	400Wx400H	74	1687-1706/24

AS1386 - Capacity @ 0.6m/s face velocity * Standard petroleum jelly or optional Blu Jel seal. ** Round spigots are 130mm long; rectangular spigots, 80mm long. Ceiling opening sizes are 685x685, 985x685, 1285x685.



Low Profile Fluid Seal Fan Filter Module

(Filter, fan and controls accessible from room)

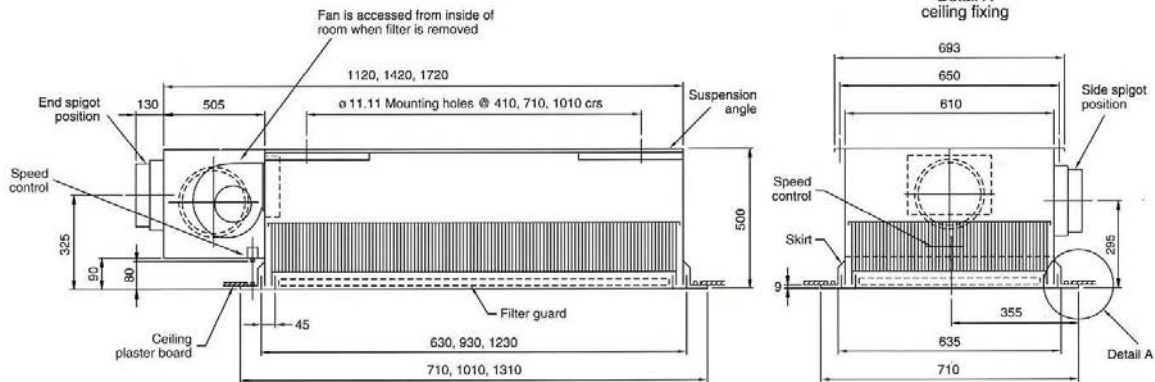

Engineering data

Clean capacity(L/s)	+125Pa capacity(L/s)	Capacity# (AS1386)	Flow direction	Filter seal*	Nominal size (mm)			Spigot location	Spigot dia.(mm)**	Installed weight (kg)	Part number
					Length	Width	Height				
340	240	175	Supply	Fluid	610	610	500	Side	300	68	1687-1704/1
445	320	272	Supply	Fluid	910	610	500	Side	300	87	1687-1704/2
545	390	370	Supply	Fluid	1210	610	500	Side	300	100	1687-1704/3
340	240	175	Supply	Fluid	610	610	500	End	300	68	1687-1704/4
445	320	272	Supply	Fluid	910	610	500	End	300	87	1687-1704/5
545	390	370	Supply	Fluid	1210	610	500	End	300	100	1687-1704/6
340	240	175	Exhaust	Fluid	610	610	500	End	300	68	1687-1704/7
445	320	272	Exhaust	Fluid	910	610	500	End	300	87	1687-1704/8
545	390	370	Exhaust	Fluid	1210	610	500	End	300	100	1687-1704/9

AS1386 - Capacity @ 0.6m/s face velocity * Standard petroleum jelly or optional Blu Jel sealing medium. ** Spigots are 130mm long. Ceiling opening sizes are 685x685, 985x685, 1285x685.

Acoustic Fluid Seal Fan Filter Module

(Filter, fan and controls accessible from room)

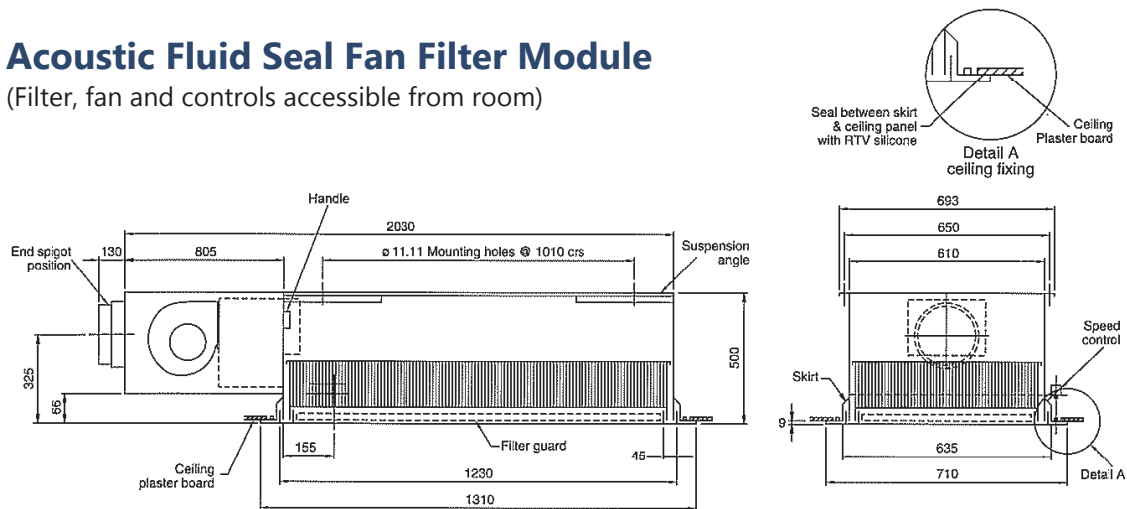

Engineering data

Capacity (L/s)	Capacity# (AS1386)	Flow direction	Filter seal*	Nominal size (mm)			Spigot location	Spigot dia.(mm)**	Installed weight (kg)	Part number
				Length	Width	Height				
290	290	Supply	Fluid	1210	610	500	End	300	110	1687-1708/1
290	290	Exhaust	Fluid	1210	610	500	End	300	110	1687-1708/2

AS1386 - Capacity @ 0.47m/s face velocity and is restricted to limit noise levels to 50dBA at 1 metre free field * Standard petroleum jelly or optional Blu Jel sealing medium. ** Spigots are 130mm long. Ceiling opening sizes are 685x685, 985x685, 1285x685.

Standard Gasket Seal Fan Filter Module

(Filter access from above only)

Standard gasket seal fan filter module
(Filter access from above only)

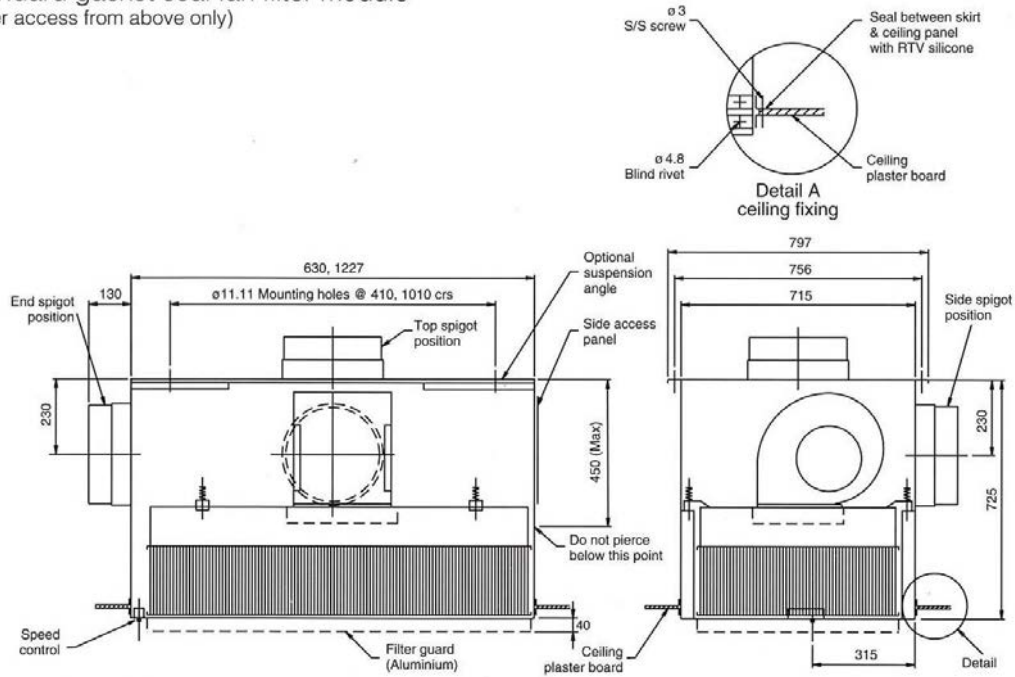

Engineering data

Clean capacity (L/s)	Capacity# (AS1386)	Flow direction	Filter seal*	Nominal size (mm)			Spigot location	Spigot dia.(mm)**	Installed weight (kg)	Part number
				Length	Width	Height				
345	245	Supply	Gasket	630	715	725	Top	300	61	1687-1520/5
345	245	Supply	Gasket	630	715	725	Side	300	61	1687-1520/6
345	245	Exhaust	Gasket	630	715	725	Side	300	61	1687-1520/6E
560	475	Supply	Gasket	1227	715	725	Top	300	91	1687-1520/7
560	475	Supply	Gasket	1227	715	725	Side	300	91	1687-1520/8
345	245	Supply	Gasket	630	715	725	End	300	61	1687-1520/9
560	475	Supply	Gasket	1227	715	725	End	300	91	1687-1520/10
345	245	Supply	Gasket	630	715	725	Both ends	300	61	1687-1520/11
560	475	Supply	Gasket	1227	715	725	Both ends	300	91	1687-1520/12
560	475	Recirc	Gasket	1227	715	725	None		91	1687-1520/13

AS1386 - Capacity @ 0.6m/s face velocity ** Spigots are 130mm long.
Ceiling opening sizes are 685x685, 985x685, 1285x685.

Range of Air Filtration Products



Nano-V™
F6, F7, F8 & F9 Rating
Sizes: 610x610 & 610x305.
Depth: 300
Xref: V-Cell, Compact Vee

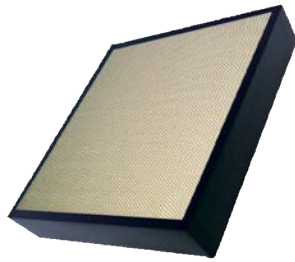

Nano-P™
F6, F7, F8 & F9 Rating
Sizes: 610x610 & 610x305.
Depth: 25, 50 & 100.
Xref: P-Pleat

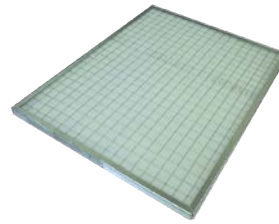

DY Filter™
F4 & F5 Rating
Sizes: 610x610, 610x305, 305x508, 508x508, 406x508, 406x635, 508x635 & custom.
Depth: 25 & 50.



V-Form™
F4 & F5 Rating
Sizes: 610x610, 610x305, 305x508, 508x508, 406x508, 406x635, 508x635 & custom.
Depth: 50 & 100.
Xref: Vee-form



Intervee™
95% Rating
Sizes: 610x610 & 610x305
Depth: 300



Interfold™
F4 Rating
Sizes: 610x610, 610x305, 305x508, 508x508, 406x508, 406x635, 508x635 & custom.
Depth: 25, 50 & 100.
Xref: G-Pleat

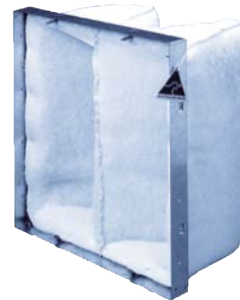

Duovee™
F4 & F5 Rating
Sizes: 610x610 & 610x305.
Depth: 400 & 600.
Xref: EX, VA320 & VA340.
Twin Cell



Fourpeak™
F4 & F5 Ratings
Sizes: 610x610 & 610x305.
Depth: 346
Xref: 4P

AIR FILTERS FOR ALL APPLICATIONS



Multippeak™
 F4 & F5 Rating
Sizes: 610x610 & 610x305.
Depth: 570
Xref: TPAC & Tricell.



Pyracube™
 F4 & F5 Ratings
Sizes: 610x610 & 610x305.
Depth: 623
Xref: EEX & ES Series.

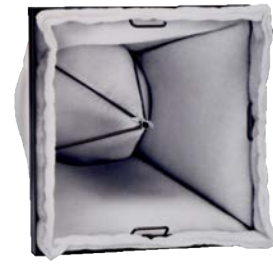

Pyracone™
 F4 & F5 Rating
Sizes: 610x610 & 610x305.
Depth: 660
Xref: EX.



Inter-Firm™
 F6, F7, F8 & F9 Rating
Sizes: 610x610 & 610x305.
Depth: 150 & 300.



Interpocket™
 F5, F6, F7, F8 & F9 Ratings
Sizes: 610x610 & 610x305.
Depth: 360, 560 & 720.
Xref: Multi-wedge & Univee

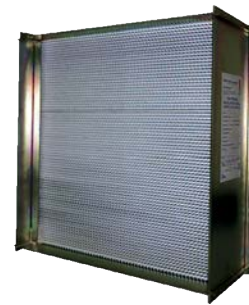

HEPA /Absolute™
 99.999% & 99.995% Rating
Sizes: Various standard sizes & custom available on request.
Depth: 149 & 292.

THE COMPANY

AES Environmental is an Australian owned manufacturing business producing products under Clyde-Apac, Email Air Handling and IFC brand names for industries that are as varied as industrial plants, commercial buildings, power stations, food processing, healthcare, science and electronics. AES Environmental, a trusted manufacturer capable of delivering reliable product solutions to highly-critical applications, where the control of hazardous airborne contamination is often critical to process and personnel.

© 2023 AES Environmental | Bulletin No. 23F.02.17 AESUK121 REV3

In keeping with our policy of continuing product improvement, we reserve the right to alter specifications without notice.



Unit 5 Arcot Court, Cramlington,
 NE23 1BB
 Ph 01670 712 112
 sales@clydeapac.co.uk
 www.aesenvironmental.co.uk

